

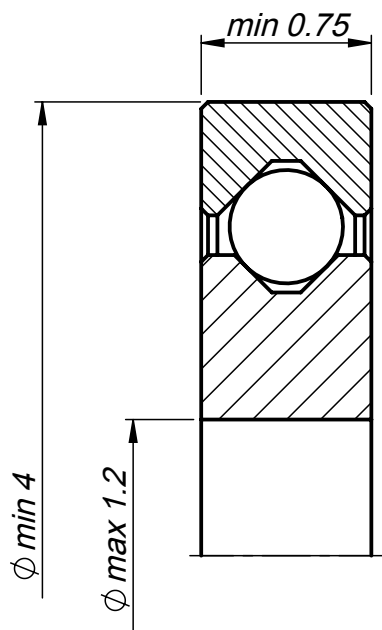

SW

We reserve all right in connection with this document and in the subject thereof. By acceptance of the document the recipient acknowledges these rights and undertakes not to publish the document nor the subject thereof in full or in part, nor to make them available to any third party without our prior express written authorization, nor to use it for any purpose other than for which it was delivered to him.

Ø Primitif	2.90 mm
Ø Bille	0.50 mm
Nb de Billes	7
Jeu axial	6 / 14 µm
Angle de balancement max	0.58°



Angles non coté: 0.03x45°

Remplace		Usinage général		Dessiné	Date	Désignation	Echelle
				ZWA	04.02.2009		
Matière			Remarque		Contrôlé	Ensemble \ Projet	Page
Modifié	Libéré	Cotes en mm - Tolérances en µm Tolérances générales: ISO 2768- fH Tolérances des angles: ± 2°				50 - 290	01
RB: .		 <b>MPS Micro Precision Systems AG</b>					
Date: 03.03.2009							
Visa:zwahlenm							